

- Not Advertised in the Trade Press -

HUDSON

HUDSON'S imprints

MACHINERY
CONSUMABLES
EQUIPMENT

Customer Newsletter - May 2003

EUROFOLD  **SWISS
MADE**

Modular Folding Technology

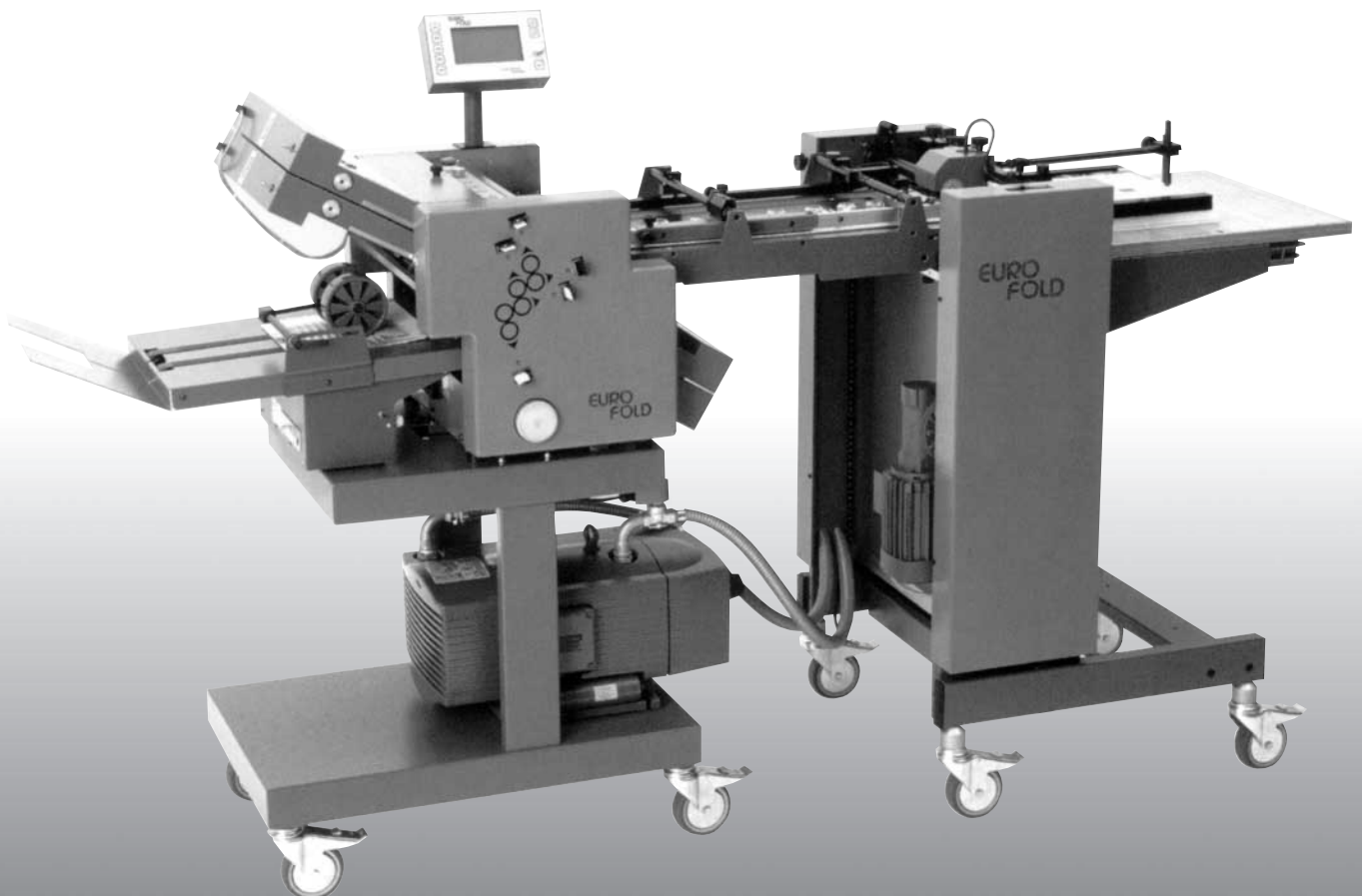

- Automatic fold plate adjustment
- Menu guided control unit
- Size change to a new job in seconds
- Recurring jobs easily stored in the computer memory

See at **printEX**  **Hudson's Stand #64**

Near-line Booklet Making with Digital Printers

such as:

Xerox, Canon, Océ or Indigo

Features of the DUPLO DSF-2000 are:

- Ability to merge pre-collated black & white digital output with a colour cover.
- A sheet counter and end-of-set mark recognition.
- Both in-line and off line finishing options.
- Complete set integrity with optional bar code reader.
- With a Duplo Bookletmaker and Trimmer users can transform pre-collated sheets into professional booklets.



**DSF-2000 Document Sheet Feeder
DBM-120SxS Bookletmaker
DBM-120T Trimmer**

Digital Printing Isn't Finished Until It's Professionally Finished!

Pressroom Chemistry

For the Quality & Safety Conscious Lithographic Printer

ABW-2010*

A General Purpose Blanket & Press Wash

ABW-2001* is a highly effective and efficient blanket wash that is fully water miscible. It is non-flammable with a flash point above 61°C. It will not only remove ink but it will also remove gums, paper pile caused by a build up of paper coating and paper fibre on the blanket.



FBW-2010*

Fast Blanket and Roller Wash

FBW-2001* is a fast, efficient and highly effective blanket and roller wash designed for use on all types of machines and on all blankets and rollers. It will not cause swelling or delamination of blankets and will not damage the rubber or blankets in any way.



WGW-2010*

White Gum Washout

WGW-2001* is a non-flammable, white gum plate washout solution suitable for all types of positive or negative aluminium plates. It is ideally suited for use in the press room as it quickly and effectively dissolves even the heaviest ink film on the plate and, at the same time, protects its surface against oxidation thereby keeping the image area ink receptive.



AEH-2010*

Plate Cleaner

AEH-2001* will thoroughly clean all types of multimetal and aluminium positive and negative baked or unbaked plates removing dried ink, scum and light scratches. It also has a desensitising effect keeping the image in an ink receptive condition and is non-flammable. Comes in one litre size only.



DER-2001*

Deglazer and Blanket Rejuvenator

DER-2001* offers a one step cleaning process where previously several steps were necessary to achieve the desired result. It cleans and revives rubber blankets, restores their original resiliency and removes items such as glaze, dried ink, gum residues, paper lint and dust.



ADC-2001*

Aqua Dampener Cleaner

ADC-2001* is a water based, highly effective dampener cover cleaner. It has a powerful cleaning effect and will remove all ink from rollers and dampener covers. It is very mild and harmless to the skin, non-corrosive and totally safe to use. Suitable for both manual and machine use.



A. E. HUDSON PTY. LIMITED • INCORPORATING GRAPHIC IMPORTS

A.B.N. 52 004 432 286

www.hudsons.com.au



SYDNEY: JAMES & EAST STS
LIDCOMBE NSW 2141
TELEPHONE: (02) 9643 8200
Email: info@hudsons.com.au
FAX: (02) 9643 8211

MELBOURNE: 26 CEYLON STREET
NUNAWADING VIC 3131
TELEPHONE: (03) 9894 3434
Email: melb@hudsons.com.au
FAX: (03) 9894 3553

BRISBANE: 18 EDMONDSTONE ROAD
BOWEN HILLS QLD 4006
TELEPHONE: (07) 3252 8212
Email: bris@hudsons.com.au
FAX: (07) 3252 5367

QLD COUNTRY: (07) 5575 5077
ADELAIDE: (08) 8363 4466
PERTH: (08) 9388 3040
TASMANIA: (03) 6234 5622

Please note all material contained in this publication is subject to copyright and may not be reprinted in whole or in part without the express permission of A.E. Hudson Pty Ltd.
* Prices quoted by A.E. Hudson Pty Ltd are trade prices and do not include GST. Limited stock is available on specials. Freight and GST are additional.